

Instruction Manual

Congratulations on your purchase! To get optimum performance from your Pearl drum set, please read this Instruction Manual first before playing.

■ Contents

• Bass Drum Shell	x1	• Cymbal Stand	x1
• Bass Drum Heads	x1pr	• Drum Throne	x1
• Bass Drum Hoops	x1pr	• Sticks	x2pr
• Bass Drum Tension Rods, Hooks	x16	• Stick Bag	x1
• Tom Tom (S)	x1	• Tuning Key	x1
• Tom Tom (L)	x1		
• Floor Tom Shell	x1	Optional:	
• Floor Tom Heads	x1pr	• Cymbal Boom Stand	x1
• Floor Tom Hoops	x1pr	• Hi-Hat Cymbal	x1
• Floor Tom Tension Rods	x12	• Crash Cymbal	x1
• Floor Tom Legs	x3	• Ride Cymbal	x1
• Hi-Hat Stand	x1		
• Drum Pedal	x1	Spare Parts:	
• Snare Drum	x1	• Lug Nut & Grease	x1
• Snare Stand	x1	• Bass Drum Tension Rod	x1
		• Floor Tom Tension Rod	x1

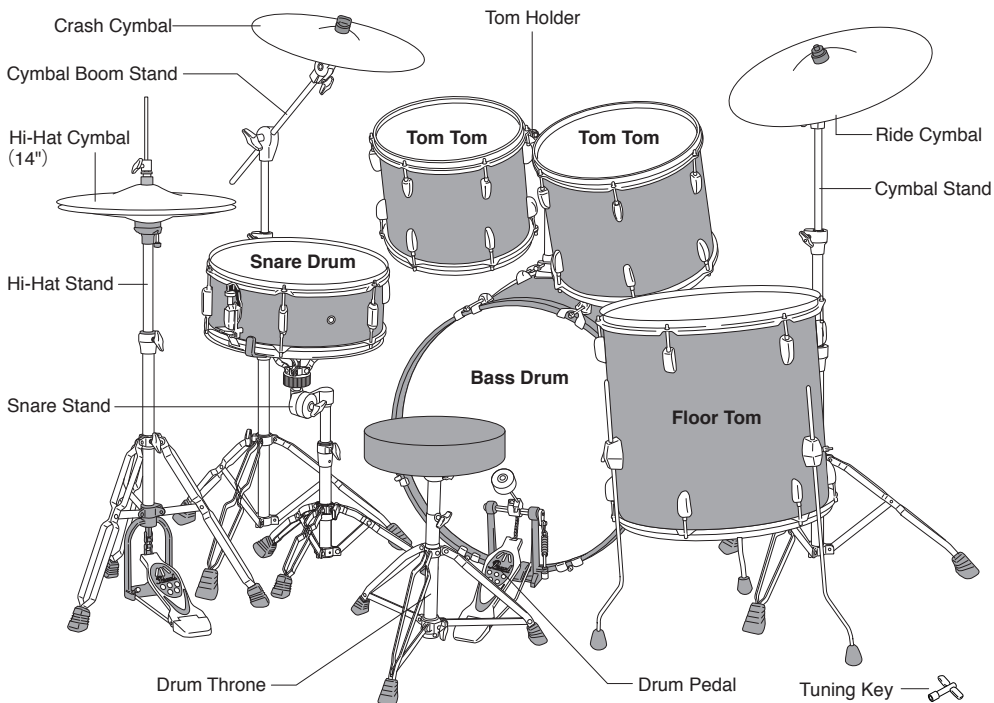

Bass Drum Assembly

The bass drum is shipped unassembled. Please follow the assembly instructions below.

1. Place the shell with the bass drum spurs facing upward on a clean, solid surface. Put the Pearl logo head on the shell, followed by the hoop with the inlay seam positioned between the bottom two lugs (Fig.1).
2. Insert a tension rod through the hook and place it on the hoop then finger tighten the tension rod into the lug nut of the lug. Attach the rest of the tension rods/hooks on this side of the drum.

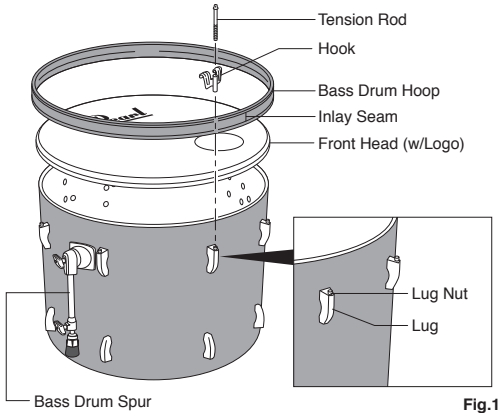

Fig.1

3. Turn the drum over and attach the other head and hoop using the remaining tension rods/hooks (Fig.2).

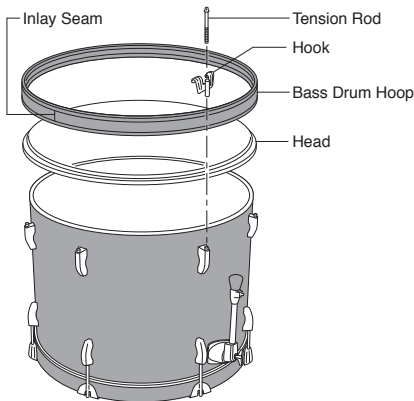

Fig.2

4. Position the bass drum upright and set the bass drum spurs as shown with the front of the drum about an inch off the floor (Fig.3). The bass drum spurs have spike tips (for added slip resistance) that can be exposed by turning the lock nut and rubber tip clockwise.

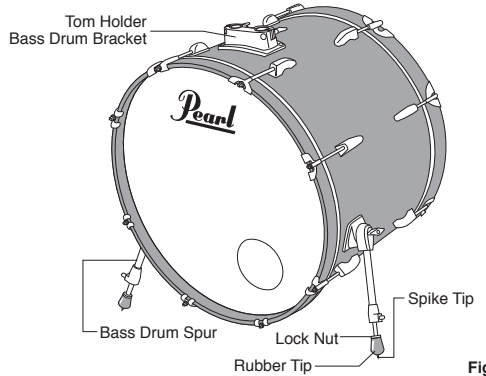

Fig.3

CAUTION

The Spike Tips are sharp. Be careful not to hurt yourself or others when using them. Use the Spike Tips only on thick carpeted surfaces to prevent damage to the flooring underneath.

Tom Tom Assembly

1. Insert the two tom holders into the bracket on the bass drum as shown (Fig.4). The tom holders are equipped with StopLocks that lock into the brackets on the bass drum and toms. The StopLocks keep the drums from rotating and memorize position settings for quick and repeatable set-ups. Position the tom holders into the tom holder bass drum bracket as shown in (Fig.4).
2. Attach the toms to the tom holders and position the height and angles to your preference. When satisfied, set the StopLocks into the slots in the tom holder brackets to retain these settings.

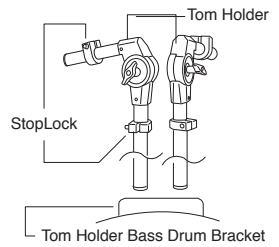
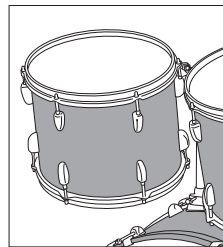

Fig.4

TIP

To smoothly attach the Tom-Tom onto the Tom Holder or Tom Holder into the Tom Holder Bass Drum Bracket, grasp the Wing-Bolt on the respective Bracket and pull away from the bracket slightly while inserting the Tom Holder (if needed loosen the Wing-Bolt and repeat.) (Fig.5).

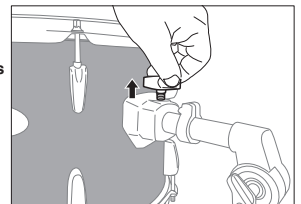

Fig.5

Floor Tom Assembly

The floor tom is shipped unassembled. Please follow the assembly instructions below.

1. Loosen and remove the two tension rods and hoops, as shown (Fig.6). Retain the tension rods for the drum head and hoop installation.

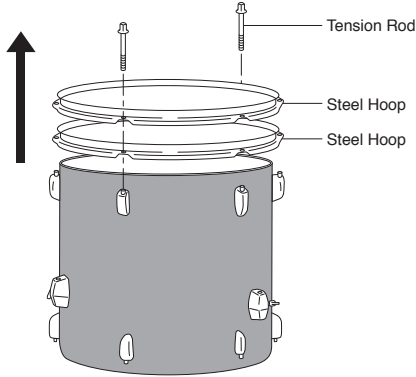

Fig.6

2. Place the shell with the floor tom leg brackets facing downward on a clean, solid surface. Put the head on the shell followed by the steel hoop (Fig.7).
3. Insert a tension rod through an ear of the steel hoop and into the lug nut of the lug (finger-tight.) Attach the rest of the tension rods in a similar manner to this side of the drum.
4. Turn the drum over and attach the other head and hoop with the remaining tension rods.
5. Attach the floor tom legs to the floor tom leg brackets as shown and set the height and tilt to your preference (Fig.8).

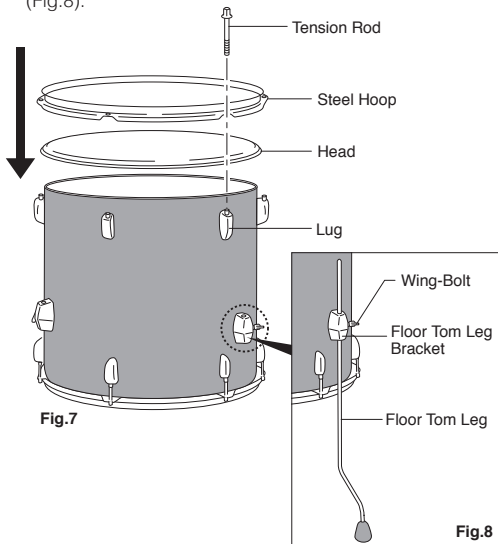

Fig.7

Fig.8

Hi-Hat Stand Assembly

Open the legs of the hi-hat to form a stable tripod. Insert the ends of the radius rod into the holes near the bottom of the hi-hat base (Fig.9). Thread the upper pull rod into the connector as shown (Fig.10).

Place the upper tube over the upper pull rod and into the tripod base and set the height to your preference. Rest the lower hi-hat cymbal on the hi-hat cup. Attach the top hi-hat cymbal to the clutch in the order shown then slide the clutch with the top cymbal attached onto the upper pull rod. Adjust the distance between the top and lower hi-hat cymbals to your preference by stepping on the pedal and tightening the wing-bolt on the clutch when the desired distance is achieved.

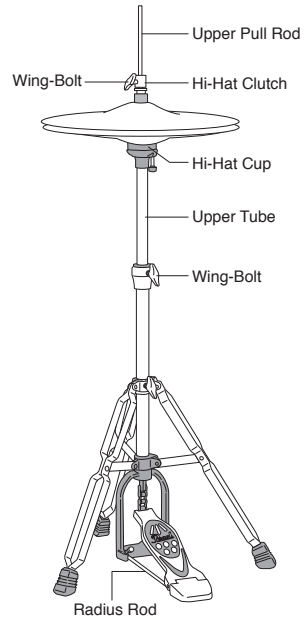
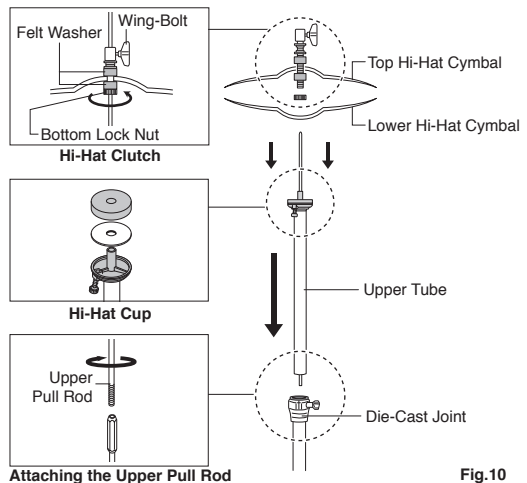

Fig.9



Attaching the Upper Pull Rod

Fig.10

Drum Pedal Assembly

Insert the ends of the radius rod into the holes near the bottom of the pedal base. With the pedal flat on the floor, insert the beater into the beater holder link and secure it with the provided tuning key (Fig. 11).

Clip the pedal to the back bass drum hoop and tighten the wing-bolt to secure the hoop clamp. Check the key-bolt at the top of the beater angle cam to ensure it is tight. Test the pedal and adjust the spring tension to your preference by adjusting the upper and lower nuts below the spring. To adjust the beater angle, loosen the key-bolt of the beater angle cam and rotate the beater to your preference and tighten. Please note this will also affect the foot-board height (Fig. 12).

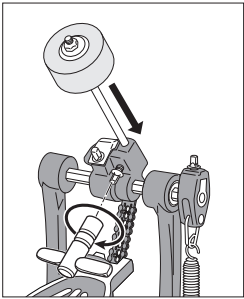
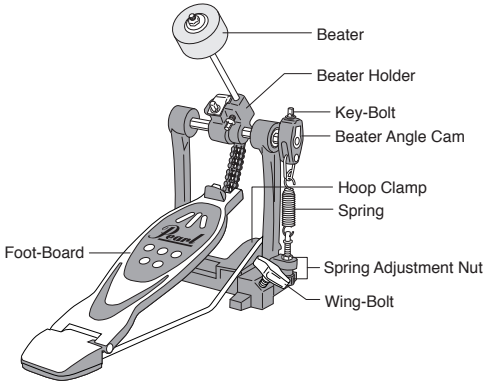

Fig.11

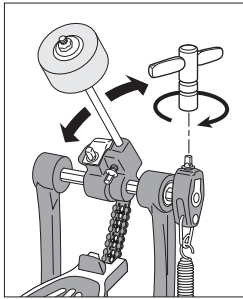

Fig.12

Snare Stand Assembly

Open the legs of the stand to form a stable tripod and insert the top section into the base. Open the basket and adjust the tilter, so the basket assembly is flat. Adjust the center knob as needed to accommodate the snare drum. Place the snare drum into the basket and tighten the center knob to secure the drum. (Do not overtighten). (Fig. 13).

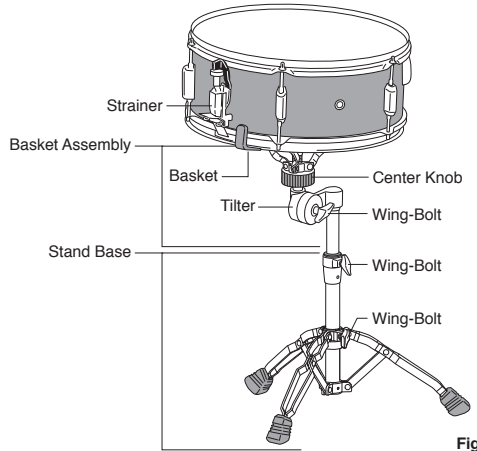

Fig.13

Please refer to the Set-Up Example on the cover page of this manual to see the completed kit.

Basic Tuning

Here is the basic tuning method using the snare drum as an example. Gradually tighten the tension bolts diagonally as shown to raise the overall pitch of the head. Tap the head at each tension rod near the rim (tuning point) as shown below and listen to the pitches.

Adjust the tuning as needed to achieve uniform pitch all around the head. Most drummers tune the bottom head of the snare drum slightly higher than the top.

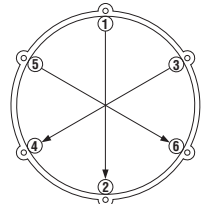

6 / Tension Rod

Basically, the tom toms and bass drum are tuned the same way as the snare drum. However, there are three ways to tune the top and bottom heads: tune both heads to the same pitch, tune the bottom head tighter than the top, or tune the bottom head looser than the top. Experiment to find the tuning method that works best for you.

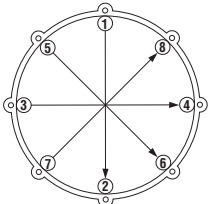

8 / Tension Rod

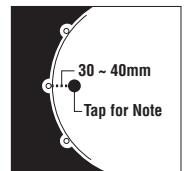

Tuning Point

If you find that the drums have too much "ring," you can control it with after-market drum heads or muffling devices. A simple and effective way to muffle your bass drum is to put a blanket or pillow inside.

USING YOUR PRODUCT SAFELY

Thank you for choosing Pearl! For proper and safe operation of your drums, stands, pedals, and accessories please follow these instructions carefully before using. Please keep these instructions in a safe place for future reference.

Display Symbols

These instructions contain symbols that are intended to alert the user and others to the possibility of danger or injury. Please make sure that you understand the meaning of the symbols before assembling and using any Pearl product.



Warning

If this symbol is ignored and the equipment is used improperly, fatal injury to persons and/or serious material damage could occur.



Caution

If this symbol is ignored and the equipment is used improperly, there is a danger of injury to persons handling the equipment, and/or material damage could occur.



Note

If this symbol is ignored and the equipment is used improperly, the performance of the equipment may be adversely affected, and/or functions may not work as designed.

- Please be aware that Pearl Musical Instrument Company accepts no responsibility for damage to equipment or other problems caused by external factors such as improper handling.

PRECAUTIONS WHEN INSTALLING EQUIPMENT



Warning

Make Sure Screws are Tightened Securely

Screws should be tightened securely to keep hardware from falling over or dropping during performance. On hardware where gears are used for angle adjustment, make sure the gears are fully meshed before the angles are secured. Failure to mesh the gears properly and securely could make the hardware unstable and cause it to tip over or drop during performance.

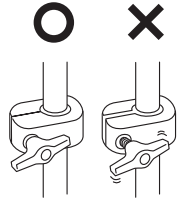

Caution

Be Careful Not to Scratch or Damage Floor Surfaces

The bass drum legs and hi-hat stand have sharpened tips/anchors that prevent slippage during performance. Handle them carefully to avoid injury. The rubber tips on the bass drum spurs and hi-hat may discolor floor surfaces if left in place for long periods of time. We recommend installing your kit on a thick carpet or specially designed drum mat to avoid damage to the surface of the floor or other floor coverings.

Make Sure Equipment Cannot Tip Over

To prevent stands from tipping over, make sure that the legs form a stable tripod as shown in Fig. A. When mounting a tom or boomed cymbal, position the tom or cymbal directly over a leg of the tripod for optimum stability.

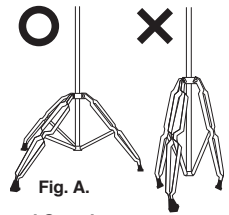

Fig. A.

Be Careful Around Drum Sets and Stands

Hardware, drums, cymbals, and percussion devices protruding from drum sets may cause people walking by or children playing nearby to trip and stumble into the drum set resulting in severe bodily injury and/or damage to equipment. Exercise extreme caution when moving about your set and closely supervise children who may be playing in the vicinity of your set.



Be Careful When Making Adjustments

Use two hands when adjusting the height and angle of drums, cymbals, practice pads, etc. Use one hand for support while making adjustments with your other hand.

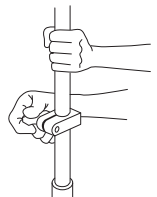

Earthquake Precautions

A strong vibration such as an earthquake can cause your drums and hardware to shift and tip over. Stay well clear of falling objects to avoid injury.

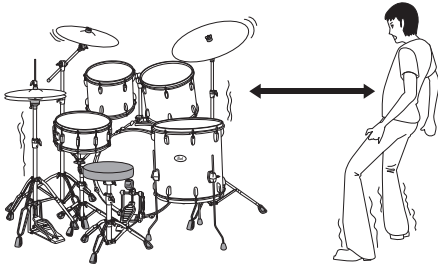

Precautions When Handling Equipment



Warning

Be Careful with Objects with Roughened or Pointed Shapes

Some parts, such as knurled posts, hi-hat rods, and tension rods have roughened or pointed shapes that can scratch surfaces or get caught, for example, on clothes or carrying bags. Please handle these parts with extra caution to avoid mishaps.

Be Careful with the Hole on Bass Drum Heads

Some bass drum heads are equipped with a hole for sound control and miking. The edges of these holes are sharp and special care must be taken when handling, miking, or muffling the bass drum to prevent injury.

Be Careful with Anti-Slip Spikes

The spikes (used on bass drum spurs, hi-hat legs, snare stand legs and some other products) are sharp and can cause serious personal or property injury. To prevent mishaps, use extreme care when handling these products especially when the spike tips are exposed. A rug or carpet should be used to protect floor surfaces whenever the spike tips are used.

Be Careful When Folding Legs on Stands

When folding the legs on stands, be careful not to pinch your fingers between the legs and the stand.

Be Careful When Handling Tubing

When handling tubular hardware do not put your fingers into the tubes to prevent injury to your fingers.

The Drum Throne is Not a Step Stool

Standing on a drum throne and using it as a step stool may cause it to break and fall over. Never use the drum throne for anything other than its designated purpose, that is, to sit on while playing.



Be Careful When Adjusting Throne Settings

Sitting on a drum seat while adjusting height settings can cause the seat to drop suddenly and pinch your fingers and/or cause other bodily injuries. Sitting on the drum seat while making adjustments may require twisting and reaching that can also cause bodily injuries. To prevent injury, perform these adjustments before sitting, test, and repeat as necessary until the best comfort/support is achieved.

Be Careful Using Sticks and Wire Brushes

Sticks and wire brushes are intended for playing the drums and should never be used to hit or to be thrown at people. Doing so can be extremely dangerous.

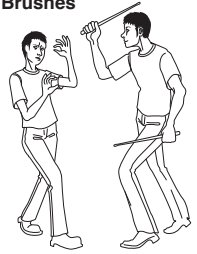

Broken Sticks

Fragments/splinters from broken drum sticks can cause injury to the player and/or to those nearby.



Caution

Precautions with Oil and Grease

Hardware such as wing nuts and wing bolts are lubricated at the factory with grease or oil. Be careful not to get these lubricants on your clothing.

Precautions with Rust or Sharp Edges

Metal parts may become rusty and scratched through use. Rusty surfaces can be sharp and care must be taken to prevent injury to your hands and feet. Metal surfaces, such as footboards, may develop sharp edges from contact with other stands, especially during transport. Examine metal parts periodically and repair immediately to prevent injury to your hands and feet.



Note

Metal Care

Should rust occur, remove the rust with commercial rust removal products and use caution to prevent cuts to hands from sharp edges that may be present.

Precautions Regarding High Temperatures and Humidity

To maintain the pristine condition of your drums and hardware, store them in places with controlled temperature and humidity (68 - 75F and 40% - 60% relative humidity is ideal).

Precautions Regarding High Temperatures and Ultraviolet Light (UV from the Sun)

To maintain the pristine condition of your drum finish covering, avoid long periods of exposure to Ultraviolet Light (direct Sun-Light) or very high temperatures.

California Proposition 65



Pearl

<http://www.pearldrum.com>

Products and specifications are subject to change without notice.

Printed in China

-202007-